

REVISIONS

APPROVALS

DESCRIPTIONS

BY

DATE

APPROVED

COUNCIL RESOLUTION NO. 26-92

3/10/92

MINIMUM R/W: 40' EXISTING ROADS
50' NEW ROADS

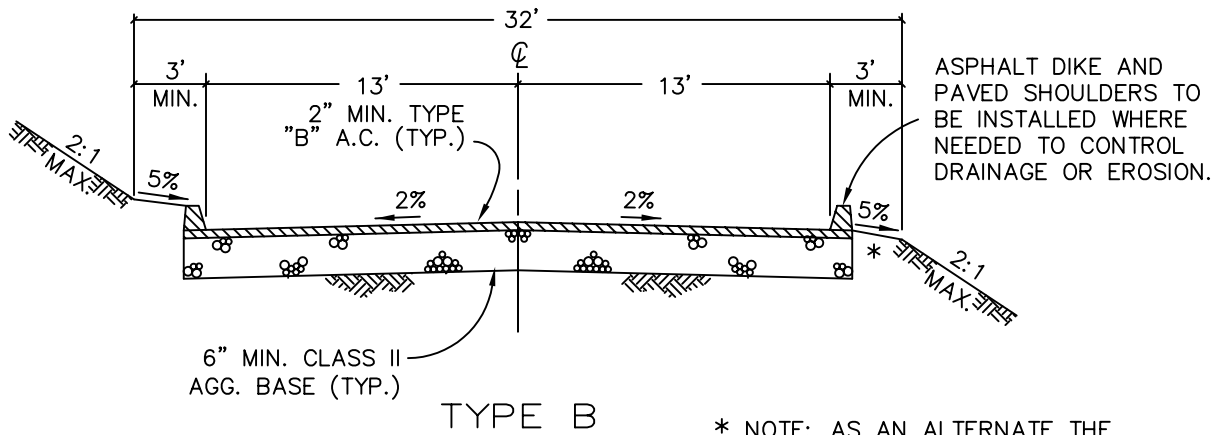
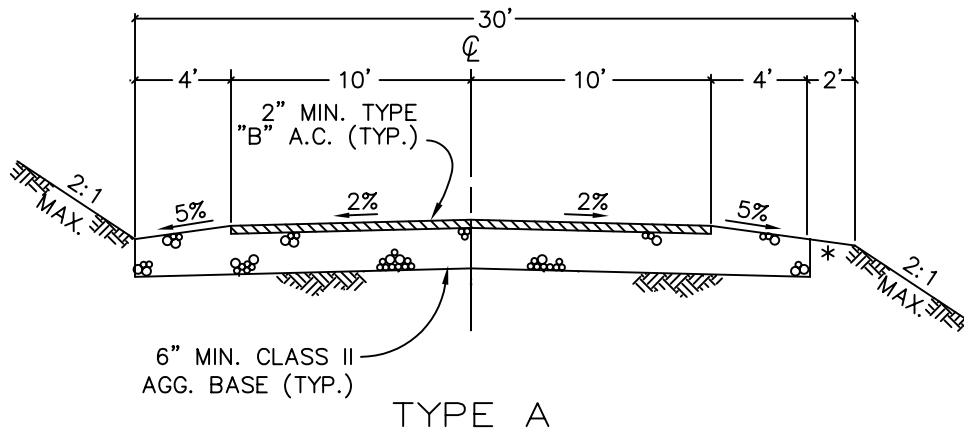

* NOTE: AS AN ALTERNATE THE CHOKER CAN BE ELIMINATED AND THE AGG. BASE CARRIED TO THE HINGE POINT.

DRAWN BY:
R.A.L.
DESIGNED BY:
S.J.S.
DATE:
2/27/92
FILE NAME:
AT401.DWG

CITY OF ATASCADERO
ENGINEERING DEPARTMENT

TYPICAL SECTIONS
RURAL LOCAL

DRAWING NO.

401