

REVISIONS				APPROVALS	
DESCRIPTIONS	BY	DATE	APPROVED	COUNCIL RESOLUTION NO.	3/10/92

MINIMUM R/W: 40' EXISTING ROADS
50' NEW ROADS

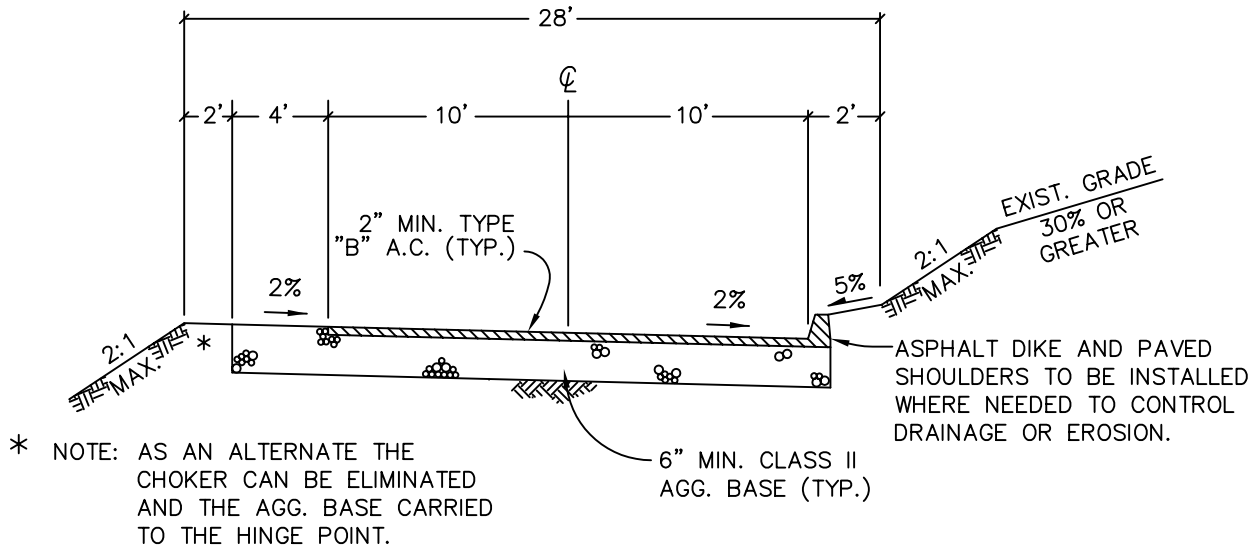

TO BE USED AS AN ALTERNATE
TO RURAL LOCAL STANDARD

DRAWN BY: R.A.L.	CITY OF ATASCADERO ENGINEERING DEPARTMENT	DRAWING NO.
DESIGNED BY: S.J.S.		402
DATE: 2/27/92	TYPICAL SECTIONS	
FILE NAME: AT402.DWG	RURAL HILLSIDE LOCAL	