

REVISIONS				APPROVALS	
DESCRIPTIONS	BY	DATE	APPROVED	COUNCIL RESOLUTION NO.	3/10/92

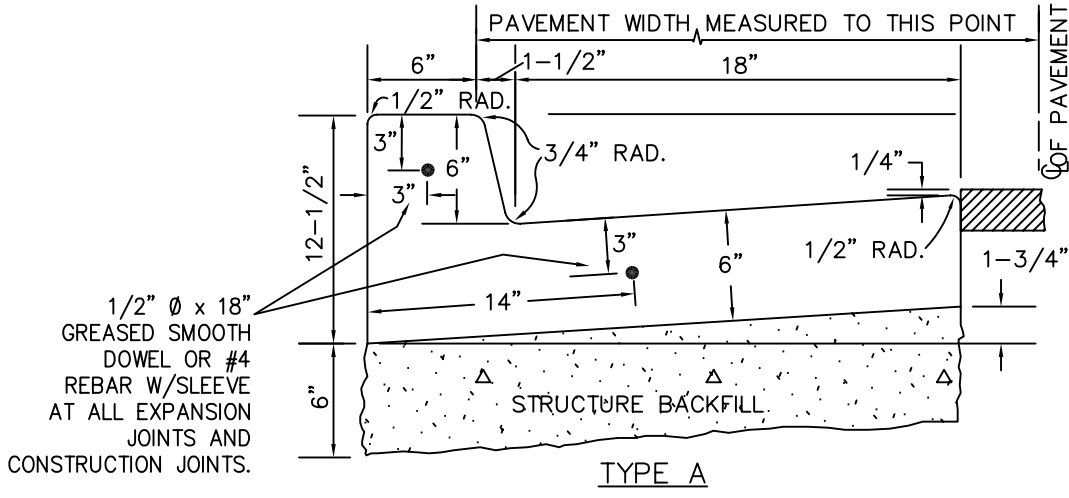
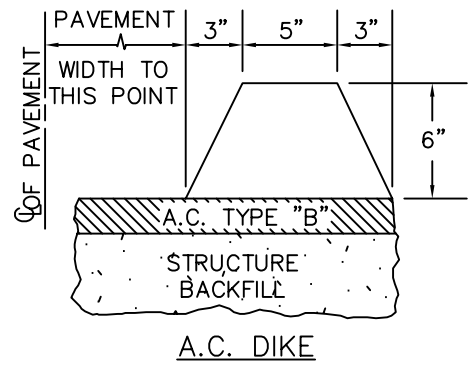
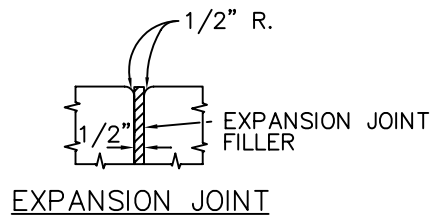
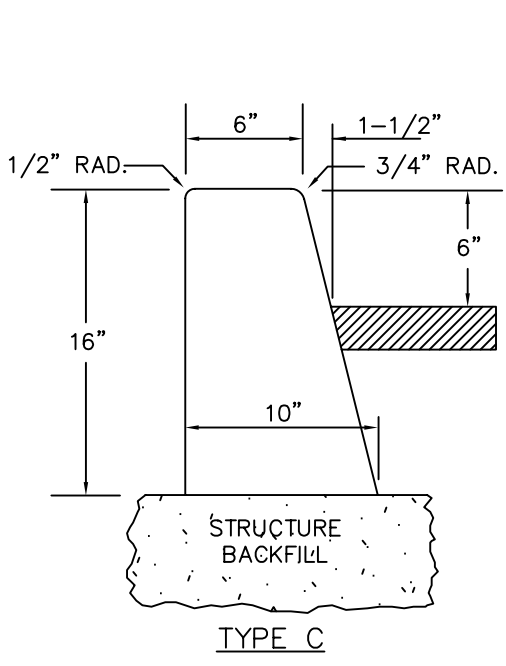

NOTE  
EXPANSION JOINTS SHALL BE PLACED AT 25' INTERVALS, AT ENDS OF ALL CURB RETURNS, AND EACH SIDE OF DRIVEWAY DEPRESSIONS. THE INTERVALS BETWEEN EXPANSION JOINTS SHALL VARY TO ALLOW MATCHING OF JOINTS ADJACENT EXISTING IMPROVEMENTS.

- NOTE
- (1) TYPE "A" AND "C" CURB TO BE CLASS 'B' P.C.C.
  - (2) DIKE TO BE TYPE 'B' A.C.
  - (3) STRUCTURE BACKFILL PER SECTION 19-3.06 STATE STANDARD SPECS.

CURING METHOD -  
CURING SHALL BE BY PIGMENTED CURING COMPOUND METHOD ACCORDING TO THE PROVISIONS OF SECTION 90-7 OF THE STATE STANDARD SPECIFICATIONS. CURING COMPOUND SHALL BE WHITE PIGMENT TYPE.

DRAWN BY: R.A.L.	CITY OF ATASCADERO ENGINEERING DEPARTMENT	DRAWING NO.
DESIGNED BY: S.J.S.		418
DATE: 2/27/92	CURBS	
FILE NAME: AT418.DWG		