

REVISIONS				APPROVALS	
DESCRIPTIONS	BY	DATE	APPROVED	COUNCIL RESOLUTION NO.	3/10/92

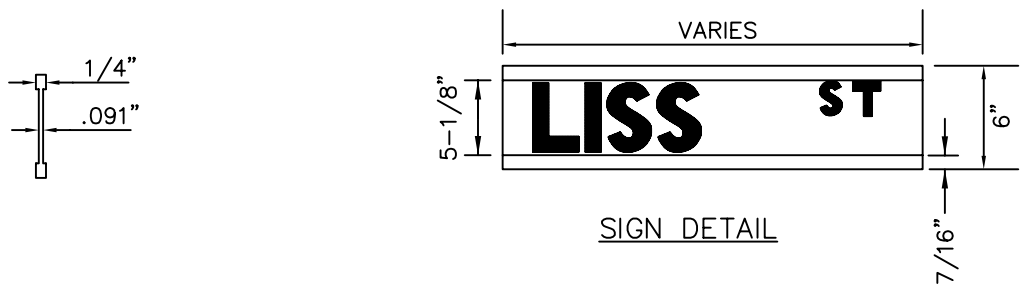

SIGN DETAIL

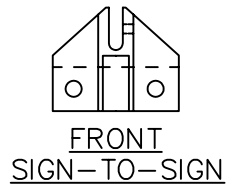
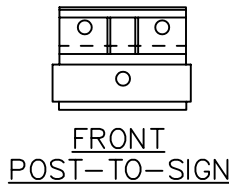
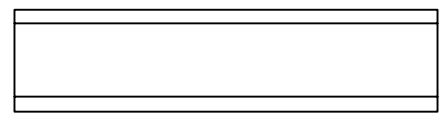

ASSEMBLY DETAIL

NOTES:

- SIGN BLADES TO BE EXTRUDED ALUMINUM, 6063-T6 ALLOY, DEGREASED AND ETCHED WITH GREEN SCOTCHLITE APPLIED TO BOTH SURFACES.
- POST-TO-SIGN BRACKET TO BE DIE-CAST, #360 ALLOY WITH TWO ANGLED GUSSETS EACH SIDE FOR STRENGTH. TO FIT 2-3/8" O.D. GALV. PIPE (2" I.D.). SIGN-TO-SIGN BRACKET TO BE SIMILAR CONSTRUCTION WITH 90° AND 45° SEPARATION.
- CAPITAL LETTERS TO BE DIE-CUT SILVER SCOTCHLITE, SERIES B.
- SCREWS FOR SECURING BRACKETS TO BE ZINC PLATED HEX SOCKET HEAD SCREWS 1/4"x1/2".

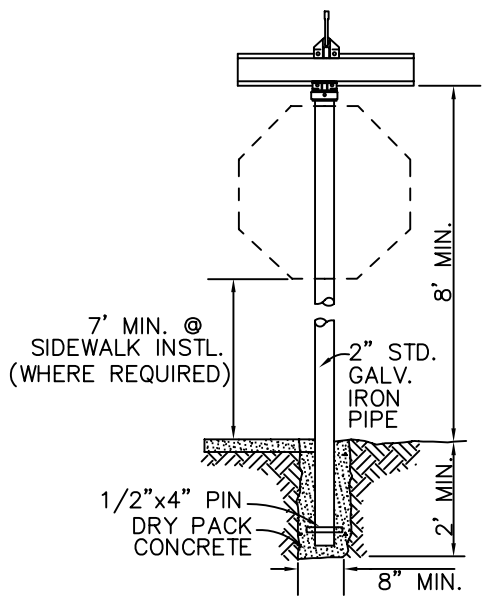

SIGN INSTALLATION

DRAWN BY: R.A.L.	CITY OF ATASCADERO ENGINEERING DEPARTMENT	DRAWING NO.
DESIGNED BY: S.J.S.		427
DATE: 2/27/92	STANDARD STREET SIGN	
FILE NAME: AT427.DWG		