

REVISIONS				APPROVALS
DESCRIPTIONS	BY	DATE	APPROVED	COUNCIL RESOLUTION

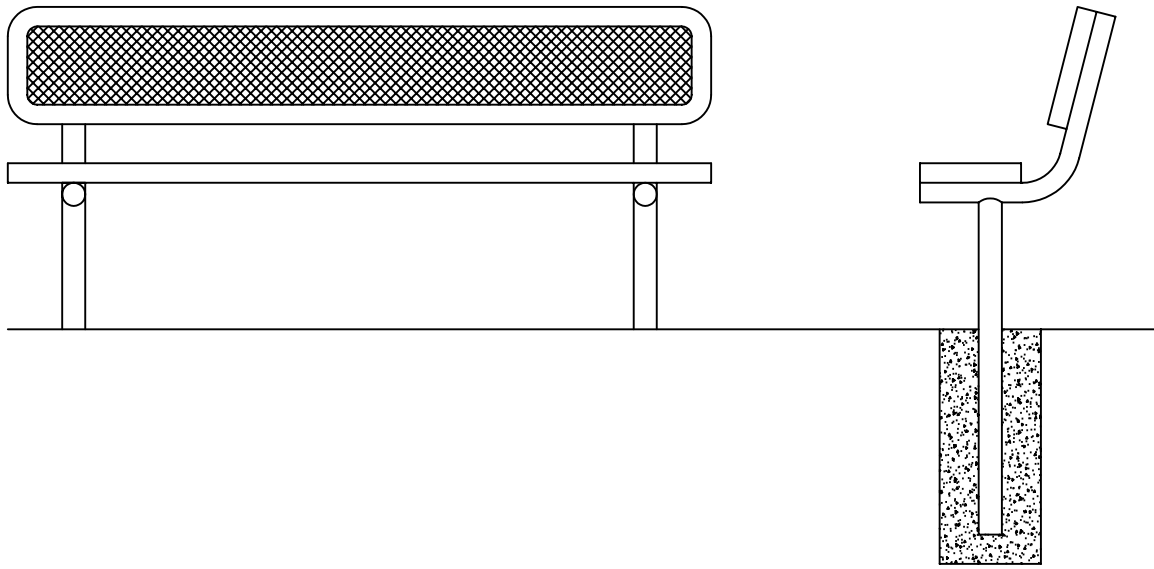

BENCH NOTES

1. BENCH SHALL BE RIVER BLUFF SERIES, TRAILSIDE BENCH, MODEL EB 6100 MANUFACTURED BY DIVERSIFIED METAL FABRICATORS, OR APPROVED EQUAL. COLOR SHALL BE APPROVED BY CITY.

CONSTRUCTION NOTES

1. FOUNDATION SHALL BE CONSTRUCTED IN ACCORDANCE WITH MANUFACTURES SPECIFICATIONS.
2. BENCH SHALL BE PLACED WITH A MINIMUM 48 INCH TRAVEL PATH IN FRONT OF BENCH. WHERE SIDEWALK IS NOT WIDE ENOUGH TO ACCOMMODATE 48 INCH TRAVEL PATH, A CONCRETE PAD SHALL BE PLACED BEHIND EXISTING SIDEWALK IN ACCORDANCE WITH CITY STANDARD DRAWING NO. 419. BENCH SHALL BE LOCATED ON NEW PAD.
3. BENCH SEAT SHALL BE INSTALLED LEVEL.

DRAWN BY: JAV	CITY OF ATASCADERO ENGINEERING DEPARTMENT	DRAWING NO.
DESIGNED BY: JAV		432
DATE: 4/10/2003	BUS STOP BENCH	
FILE NAME: AT432.DWG		